

Standard 4254L90 Package Specs:

- Rails stack on rear side of elevator shaft
- 42" wide x 54" Deep Platform Size, 80" Height
- 3/4" finished floor allowance, 3/4" birch subfloor
- Aluminum platform
- 2 LED cab lights, automatic on/off
- Brushed aluminum fixtures
- Emergency Phone
- Standard Birch wall finish
- 2 White accordion gates
- Honeywell door interlocks
- Swing doors and jambs by others.

Available Options:

- 2 Clear accordion gates
- 4 LED lights
- 2 Automatic Gate Operators
- Battery Lowering w/ Emergency Lighting
- Flush mount door jamb kit

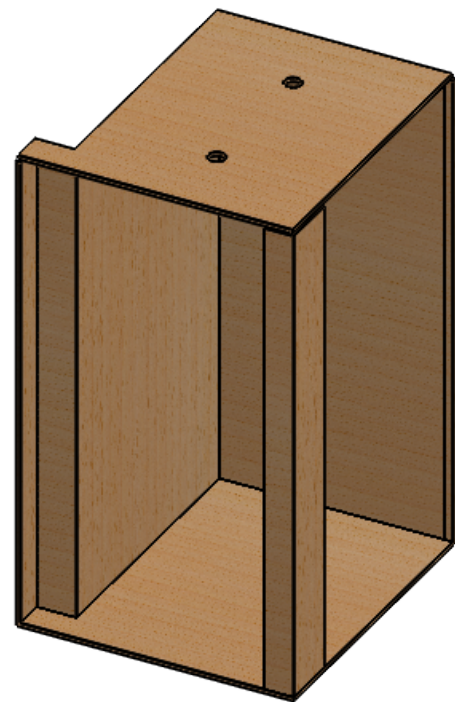

Customer Name:

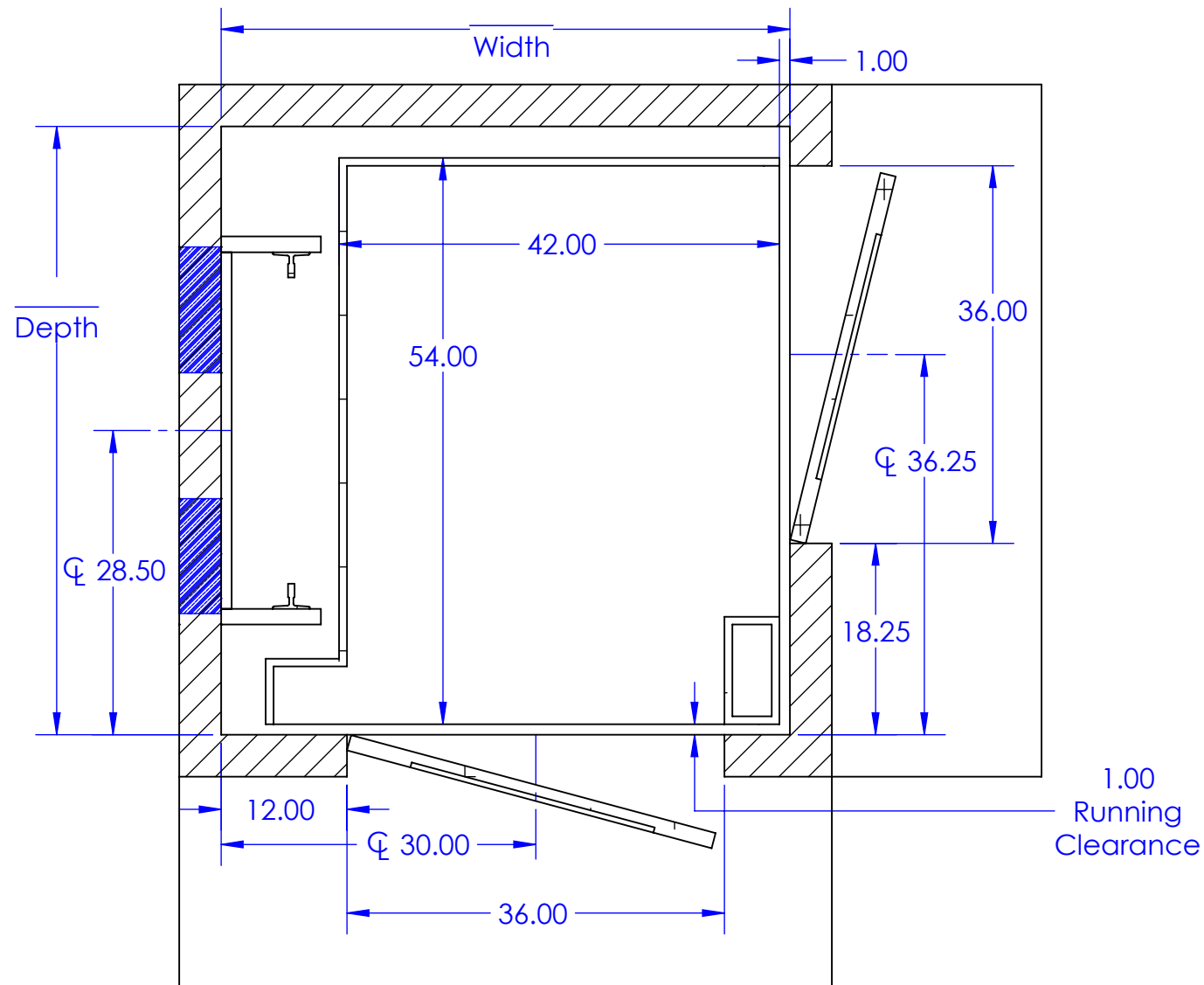

Additional Notes

Number of Landings:
 Door Swings: LH
 RH
 Cab Height:
 Cab Finish:
 Cab Style:

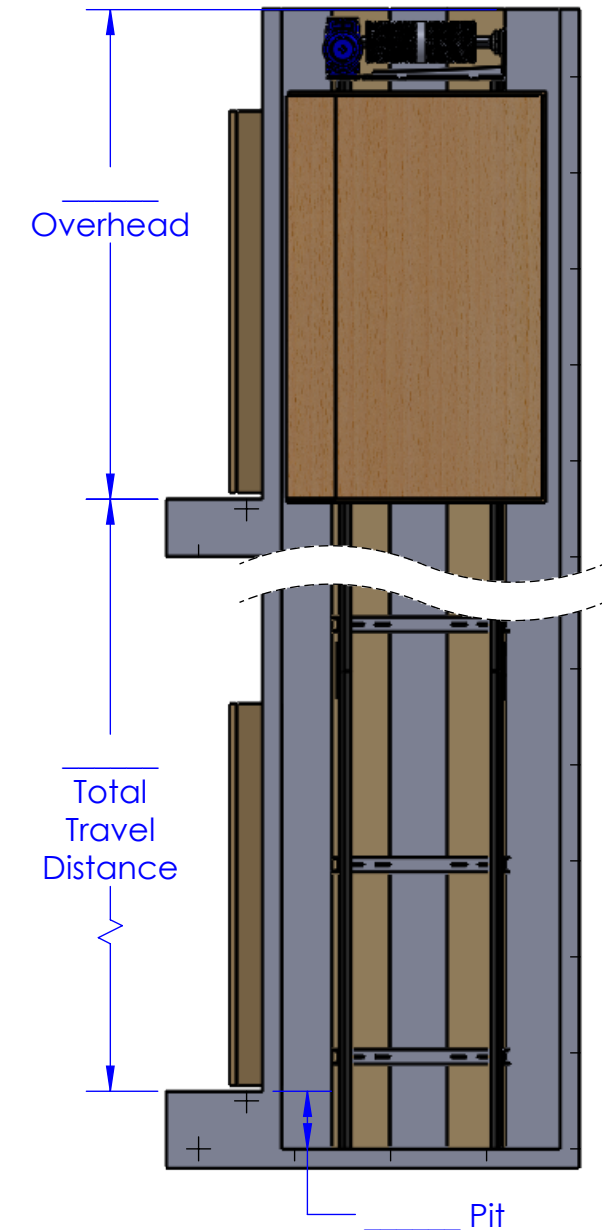

Elevator Shaft Requirements:

Pit: 12"
 Width: 54" Min 56"Max
 Depth: 58" Min

Minimum Overhead Clearance:

Cab	Overhead
80"	102"
84"	106"
95"	117"



- All swing doors must comply with ASME 17.1, National Elevator Code, 3 x 5 rule or 3/4" x 3" as required by local jurisdiction.
- Minimum shaft sizes shown.
- Consult factory for changes to door swing or offset location.
- See Rail Bracket Detail sheet for anchoring and support details.
- See Electrical Requirement sheet for electrical requirements.
- All dimensions are inside clear finished dimensions.

DRAWING NOT TO SCALE	NAME	DATE	PROJECT NAME
	Filed By		
	By signing below, you are authorizing this job to be released for production as listed.		PROJECT LOCATION
	Release for production		COMMENTS:
PROPRIETARY AND CONFIDENTIAL THE INFORMATION CONTAINED IN THIS DRAWING IS THE SOLE PROPERTY OF PRECISION LIFT INDUSTRIES, LLC. ANY REPRODUCTION IN PART OR AS A WHOLE WITHOUT THE WRITTEN PERMISSION OF PRECISION LIFT INDUSTRIES, LLC IS PROHIBITED.	PO#		
	SIZE	DWG. NO.	REV.
	A	4254L90	
SCALE 1:16			SHEET 18 OF 2

Rail Bracket Detail Sheet

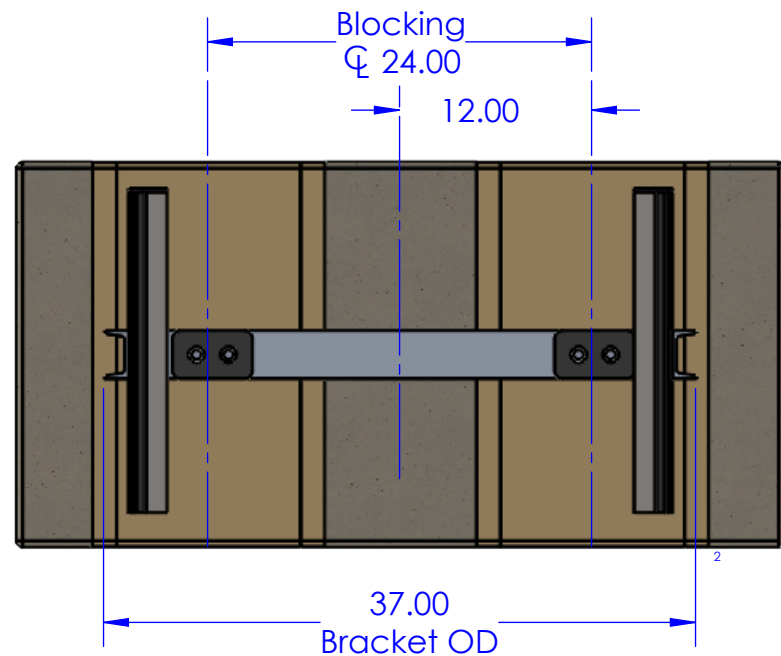

Double stacked 2x12 with 2x4 end caps running the full vertical length of the rail support wall.

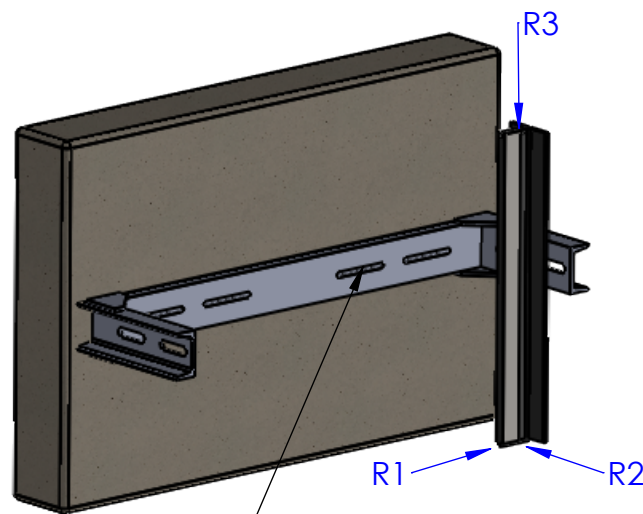
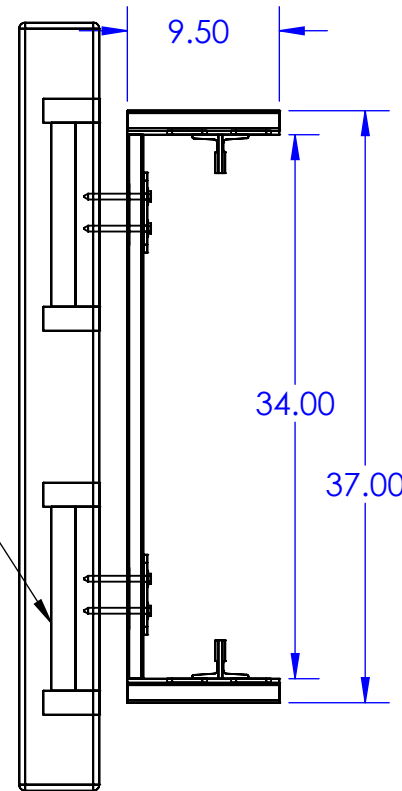

ATTACH VIA 3/8 X 4" LAG BOLTS FOR WOOD OR 3/8 x 5" WEDGE ANCHOR FOR CONCRETE

RAIL FORCES	
R1	105 LBS
R2	250 LBS
R3	3750 LBS

ELITE 9500 ELEVATOR Specifications

MODEL	WD-9500
CAPACITY	950 LBS
SPEED	40 FPM (Nominal)
DRIVE	3 HP GEARMOTOR W/BRAKE, 220VAC, WINDING DRUM
SAFETIES	INSTANTANEOUS TYPE "A" SLACK CABLE
DOOR LOCKS	ELECTROMECHANICAL, HONEYWELL RELIALIGN INTERLOCKS
ELECTRICAL REQUIREMENTS	110VAC 15AMP DEDICATED CIRCUIT FED THROUGH DISCONNECT 220VAC 30AMP DEDICATED CIRCUIT FED THROUGH DISCONNECT
CONTROL SYSTEM	PLC CONTROLLER, VFD MOTOR CONTROL, OPTICAL SENSOR LANDING SYSTEM

GENERAL NOTES

MANUFACTURED IN COMPLIANCE WITH ASME A17.1.5.3, NATIONAL SAFETY CODE FOR ELEVATORS AND ESCALATORS AND NEC

Work By Others

- PLUMB, SQUARE AND LEGAL HOISTWAY BUILT TO MATCH SHOP DRAWINGS, WITH ADEQUATE SUPPORT AND DOOR OPENING IN LINE.
- 220vac, 30 AMP DEDICATED CIRCUIT, FED THROUGH LOCKABLE FUSABLE DISCONNECT
- 120VAC, 15 AMP DEDICATED CIRCUIT, FED THROUGH LOCKABLE FUSABLE DISCONNECT (DISCONNECTS MUST BE ADJACENT TO ELEVATOR CONTROLLER LOCATION)
- DEDICATED TELEPHONE LINE LOCATED ADJACENT TO ELEVATOR CONTROLLER

ELEVATOR HOISTWAY REQUIREMENTS SUBJECT TO LOCAL JURISDICTION



- All swing doors must comply with ASME 17.1, National Elevator Code, 3 x 5 rule or 3/4" x 3" as required by local jurisdiction.
- Minimum shaft sizes shown.
- Consult factory for changes to door swing or offset location.
- See Rail Bracket Detail sheet for anchoring and support details.
- See Electrical Requirement sheet for electrical requirements

DRAWING NOT TO SCALE

PROPRIETARY AND CONFIDENTIAL

THE INFORMATION CONTAINED IN THIS DRAWING IS THE SOLE PROPERTY OF PRECISION LIFT INDUSTRIES, LLC. ANY REPRODUCTION IN PART OR AS A WHOLE WITHOUT THE WRITTEN PERMISSION OF PRECISION LIFT INDUSTRIES, LLC IS PROHIBITED.

Filed By	NAME	DATE	PROJECT NAME
KSB			
By signing below, you are authorizing this job to be released for production as listed. Engineering will review dimensions and generate a FINAL APPROVED Drawing to scale and you will receive a job confirmation letter.			PROJECT LOCATION
Release for production			COMMENTS:
PO#	SCALE 1:16	SIZE DWG. NO.	REV.
		A	
			SHEET 2 of 2