



PLANNING GUIDE

builder & architect edition

ASME A17.1, Part V, Section 5.3

November 27, 2018

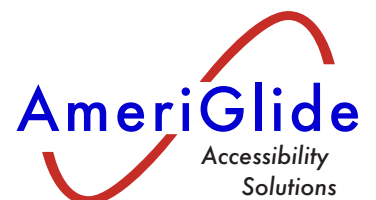

Sales: (855) 595-0281
8am-9pm EST / Every Day

All information found in AmeriGlide's Elite Elevator Planning Guide reflects information at the time of printing. AmeriGlide reserves the right to change information without notice.

VER112718

Planning Guide for the AmeriGlide Elite Elevator.

This planning guide is designed to assist architects, contractors, home owners and elevator professionals in planning for a home elevator that meets the requirements of ASME A17.1 Part V Section 5.3.

We strongly recommend you contact the codes authority having jurisdiction in the area(s) where the elevator will be installed. Become familiar with all requirements governing the installation and use of elevators in private residences. It is extremely important for you to know and adhere to all regulations concerning installation and use of elevators.

IMPORTANT NOTICE:

This Planning Guide provides nominal dimensions and specifications useful for INITIAL planning of an elevator project. BEFORE beginning actual construction, be sure to receive application drawings customized with specifications and dimensions for your specific project. Call (855) 595-0281 to find a dealer in your area or visit our website, www.ameriglide.com and click on "Request Information".

Elevator configurations and dimensions are in accordance with our interpretation of the standards set forth by ASME A17.1 Part V Section 5.3. Please consult AmeriGlide or an authorized dealer in your area for more specific information pertaining to your project, including any deviation between referenced standards and those of any local codes or laws. Always contact local codes authorities for any variation to standards.

Please note all dimensions and specifications contained herein are nominal and should only be used in the early planning stages. Construction of the actual hoistway and related Elite Elevator requirements should be based off job-specific application drawings.

This elevator requires 230 VAC, single phase 60 Hz circuit with ground and separate 115 VAC, single phase 60 HZ circuit with ground fused 10 amp for light circuits.

Steps of planning for an AmeriGlide Elite Elevator:

1. Determine customer's intention for use.
2. Determine code requirements of site.
3. Determine installation parameters of site.
4. Determine the car type and hoistway size requirements (see pages 5 through 10).

Table of Contents

Planning Guide Intro.	2	Support Wall	10
Technical Specifications	3	Alternate Framing Options.....	10
Shaft Layouts	4	Shaft Lighting	11
36 x 36 Cab.....	4	Overhead Requirements	11
36 x 48 Cab.....	5	Access Hatch	11
36 x 60 Cab.....	6	Electrical Requirements.....	11
42 x 54 Cab.....	7	Machine Room	11
48 x 36 Cab.....	8	Controller Layout.....	12
Framing Guidelines	9	Hoistway Doors	13
		Pit Detail.....	14

Technical Specifications

MODEL	Elite
CAPACITY	950 lbs.
TYPE	Machine-Room-Less
CAB SIZES	STANDARD SIZES* 36" W x 36" D 36" W x 48" D 48" W x 36" D OPTIONAL SIZES* 36" W x 60" D 42" W x 54" D <i>Custom Sizes Available</i> <small>*Approximate I.C.D. (standard)</small>
CAB HEIGHTS	STANDARD 6' 8" (80") OPTIONAL 7' 0" (84") 8' 0" (96")
NOMINAL SPEED	40 fpm
MAX TRAVEL	48' 5"
MAX LANDINGS	7
OVERHEAD CLEARANCE REQUIRED	6' 8" cab requires 102" 7' 0" cab requires 106" 8' 0" cab requires 117" <small>Measured from top landing floor level to lowest point in elevator shaft.</small>
POWER REQUIREMENT	230V with 30amp circuit / 110V with 15amp circuit
DRIVE SYSTEM	VVVF motor controls and geared winding drum machine
PIT DEPTH	8" minimum, 12" recommended
CAR DOOR	Electromechanical door interlocks

CONTROLS & SWITCHES Automatic operation, optical leveling, industrial PLC controls, ETL listed controller, Floor buttons, alarm button in cab, hall station floor buttons, emergency stop switch

DRIVE SYSTEM **STANDARD** Overhead Winding Drum
OPTIONAL Roped Hydraulic

CAB FINISHES **STANDARD** Melamine *AVAILABLE IN: WHITE OR BLACK*

ADDITIONAL CAB FINISH OPTIONS
 Unfinished Veneer
AVAILABLE IN: UNFINISHED BIRCH, OAK, CHERRY OR MAHOGANY

Traditional Raised Moulding Panel
AVAILABLE IN: BIRCH, OAK, CHERRY OR MAHOGANY

Shaker Style
AVAILABLE IN: WHITE, UNFINISHED BIRCH, OAK OR MAHOGANY

GATES **STANDARD** White panel, accordion gates
OPTIONAL Clear panel, accordion gates

FIXTURE FINISHES **STANDARD** Polished Aluminum
OPTIONAL Muntz Bronze

HANDRAIL **STANDARD** Flat polished aluminum handrail
OPTIONAL Round Polished Aluminum

FINISHED FLOORING By others 1/4" tolerance, we supply subfloor only.

EMERGENCY Emergency phone, emergency stop switch

SAFETY Slack cable switch and wedge safeties, final limit switch, integrated interlocks, emergency stop switch. All safety features required by ASME A17.1, section 5 (National Elevator Code)

WORK BY OTHERS Plum & square shaft, pit construction, access hatch, electrical and phone.

Shaft Layouts

All dimensions are to inside finished walls.

36 x 36 Cab

Available in LH & RH Configurations

36 x 36 Cab - Left Hand Layout

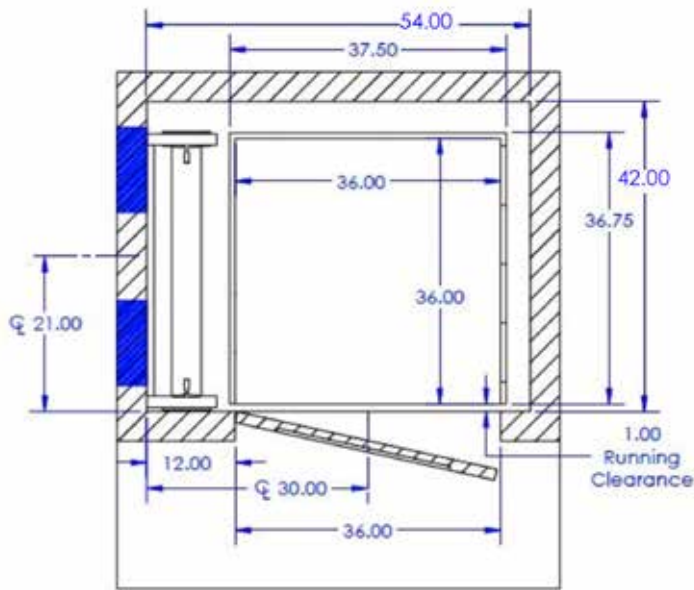

Shown above is a 36 x 36 *Left Hand (LH)* elevator layout with 12" pit (minimum dimensions shown). Door shown is considered a Right Hand swing.

36 x 36 Cab - Right Hand Layout

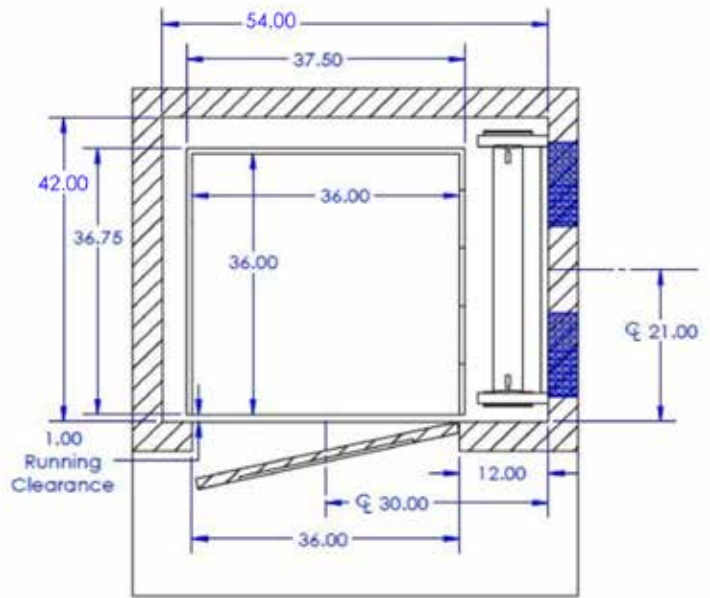

Shown above is a 36 x 36 *Right Hand (RH)* layout with 12" pit (minimum dimensions shown). Door shown is considered a Left Hand swing.

CAR SIZE	WIDTH	DEPTH	CENTER OF RAIL	CENTER OF DOOR	CLEAR OPENING
36"x36"	54"	42"	21"	30"	31.5"

MINIMUM OVERHEAD CLEARANCE	
CAB	OVERHEAD
80"	102"
84"	106"
95"	117"

ELEVATOR SHAFT REQUIREMENTS			
CAR SIZE	PIT	WIDTH	DEPTH
36"X36" L/R	12"	54" Min	42" Min

Shaft Layouts

All dimensions are to inside finished walls.

36 x 48 Cab

Available in LH, RH & Straight-Through Configurations

36 x 48 Cab - Same Side Layout

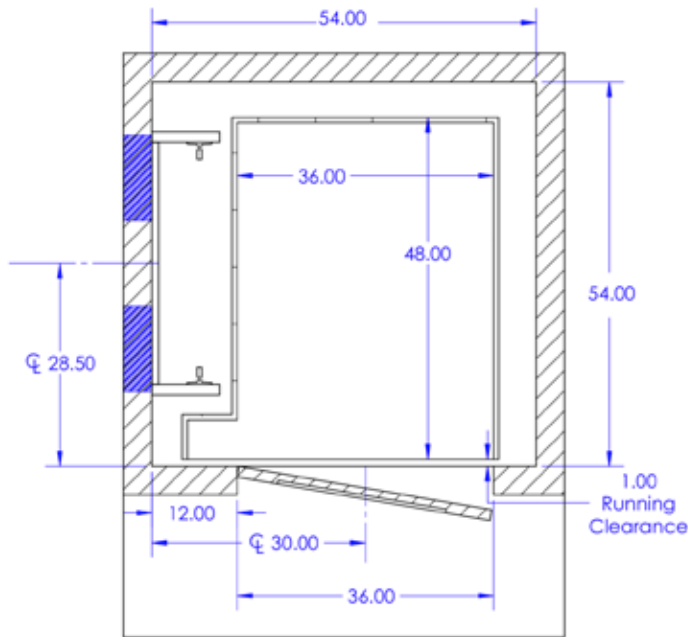

Shown above is a 36 x 48 Left Hand (LH) elevator layout with 12" pit (minimum dimensions shown). Doors shown are considered a Right Hand swing.

CAR SIZE	WIDTH	DEPTH	CENTER OF RAIL	CENTER OF DOOR	CLEAR OPENING
36"x48" (LH/RH)	54"	54"	28.5"	30"	36"

36 x 48 Cab - Straight Through Layout

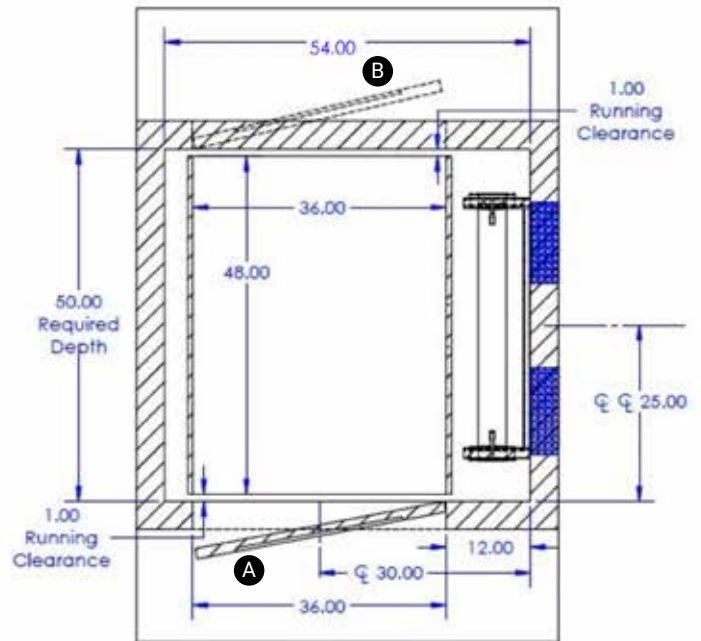

Shown above is a 36 x 48 Straight Through (ST) layout with 12" pit (minimum dimensions shown). Two doors shown: A) Left Hand swing and B) Right Hand swing.

CAR SIZE	WIDTH	DEPTH	CENTER OF RAIL	CENTER OF DOOR	CLEAR OPENING
36'x48" (PT)	54"	50"	25"	30"	31.5"

ELEVATOR SHAFT REQUIREMENTS			
CAR SIZE	PIT	WIDTH	DEPTH
36"X48" L/R	12"	54" Min	54" Min
36"X48" PT	12"	54" Min	50" Critical

MINIMUM OVERHEAD CLEARANCE	
CAB	OVERHEAD
80"	102"
84"	106"
95"	117"

Shaft Layouts

All dimensions are to inside finished walls.

36 x 60 Cab

Available in LH, RH & Straight-Through Configurations

36 x 60 Cab - Same Side Layout

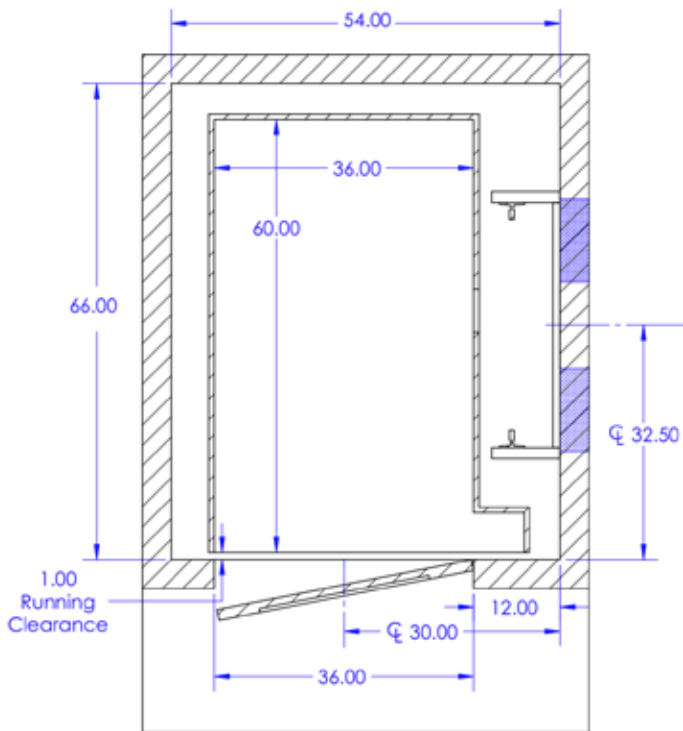

Shown above is a 36 x 60 *Right Hand (RH)* elevator layout with 12" pit (minimum dimensions shown). Door shown is considered a Left Hand swing.

CAR SIZE	WIDTH	DEPTH	CENTER OF RAIL	CENTER OF DOOR	CLEAR OPENING
36" x 60" (LH/RH)	54"	66"	32.5"	30"	36"

36 x 60 Cab - Straight Through Layout

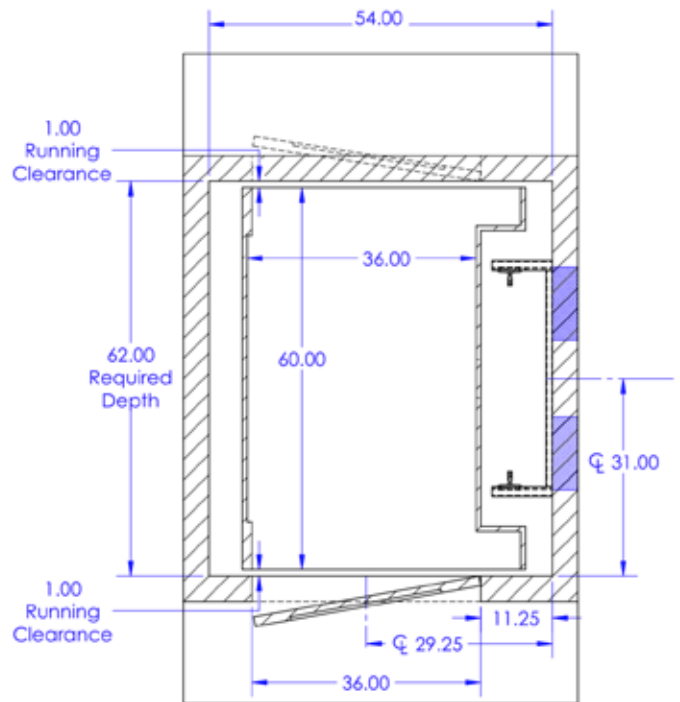

Shown above is a 36 x 60 *Straight Through (PT)* layout with 12" pit (minimum dimensions shown). Two doors shown: A) Left Hand swing and B) Right Hand swing.

CAR SIZE	WIDTH	DEPTH	CENTER OF RAIL	CENTER OF DOOR	CLEAR OPENING
36" x 60" (PT)	54"	62"	31"	29.25"	36"

ELEVATOR SHAFT REQUIREMENTS			
CAR SIZE	PIT	WIDTH	DEPTH
36" X 60" L/R	12"	54" Min	66" Min
36" X 48" PT	12"	54" Min	62" Critical

MINIMUM OVERHEAD CLEARANCE	
CAB	OVERHEAD
80"	102"
84"	106"
95"	117"

Shaft Layouts

All dimensions are to inside finished walls.

42 x 54 Cab

Available in LH & RH Configurations

42 x 54 Cab - Left Hand Layout

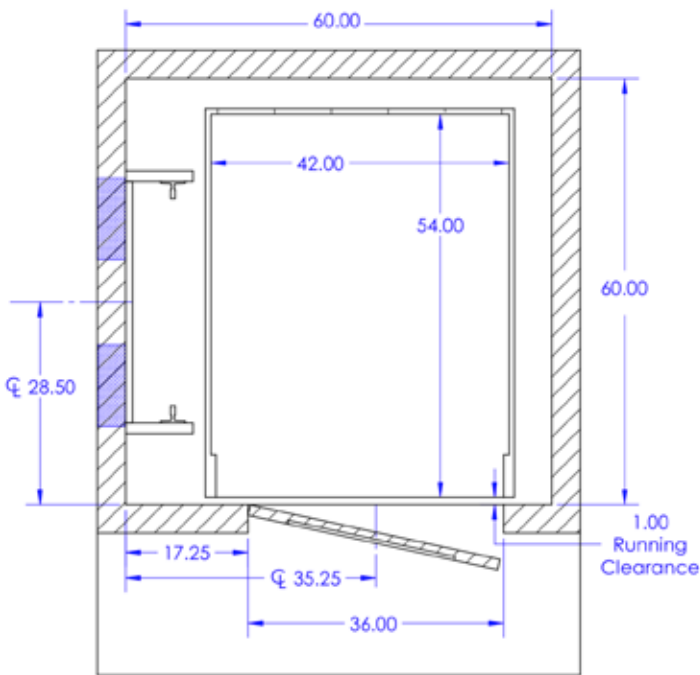

Shown above is a 42 x 54 Left Hand (LH) elevator layout with 12" pit (minimum dimensions shown). Door shown is considered Right Hand swing.

42 x 54 Cab - Right Hand Layout

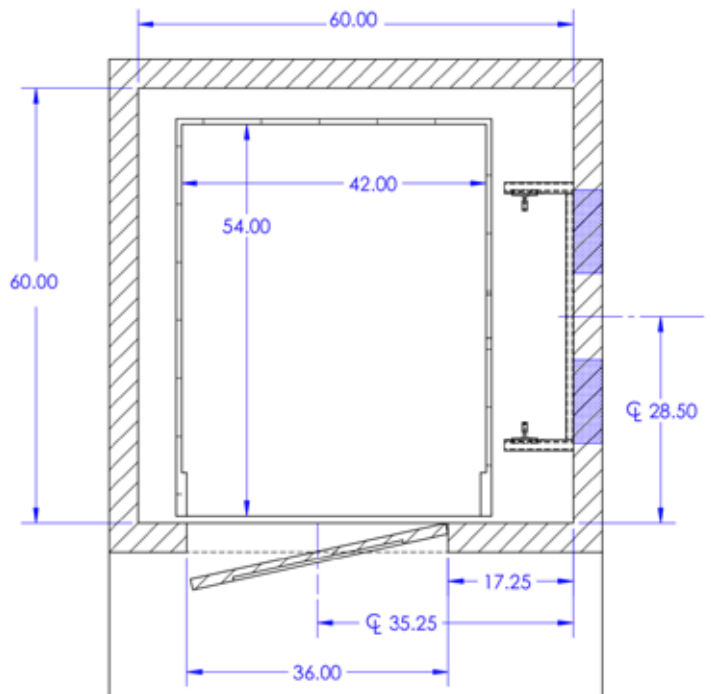

Shown above is a 42 x 54 Right Hand (RH) layout with 12" pit (minimum dimensions shown). Door shown is considered a Left Hand (LH) swing.

CAR SIZE	WIDTH	DEPTH	CENTER OF RAIL	CENTER OF DOOR	CLEAR OPENING
42" x 54"	60"	60"	28.5"	35.25"	36"

MINIMUM OVERHEAD CLEARANCE	
CAB	OVERHEAD
80"	102"
84"	106"
95"	117"

ELEVATOR SHAFT REQUIREMENTS			
CAR SIZE	PIT	WIDTH	DEPTH
42" X 54" L/R	12"	60" Min	60" Min

Shaft Layouts

All dimensions are to inside finished walls.

48 x 36 Cab

Available in LH & RH Configurations

48 x 36 Cab - Left Hand Layout

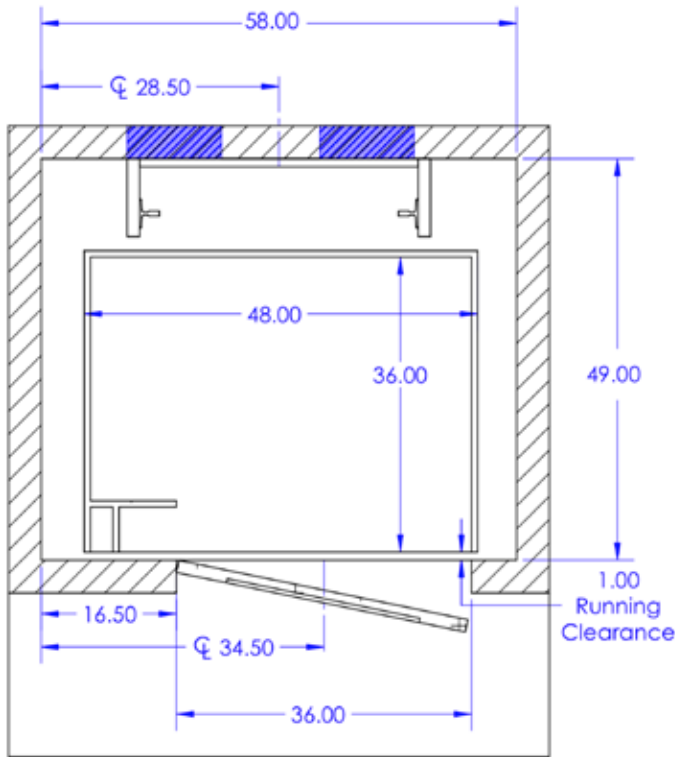

Shown above is a 48 x 36 *Left Hand (LH)* elevator layout with 12" pit (minimum dimensions shown). Door shown is considered *Right Hand* swing.

48 x 36 Cab - Right Hand Layout

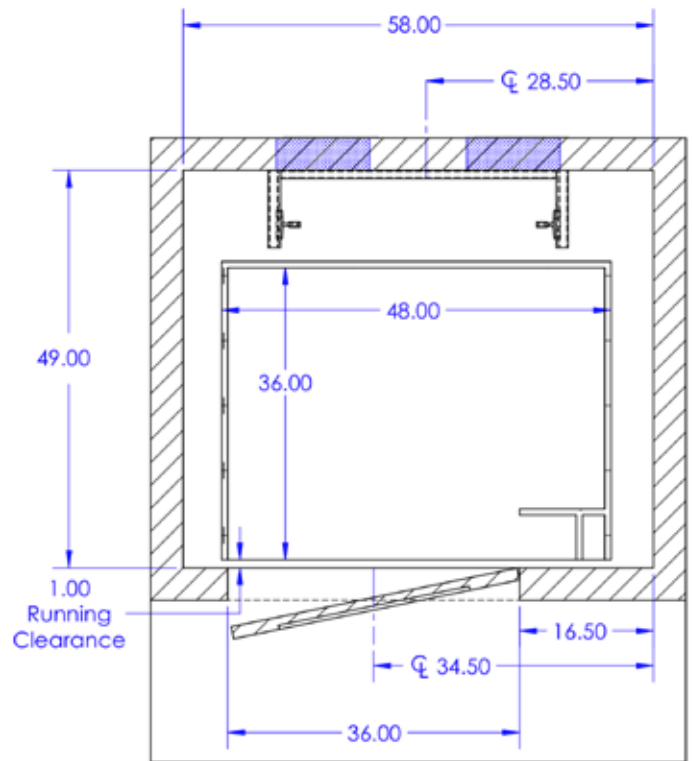

Shown above is a 48 x 36 *Right Hand (RH)* layout with 12" pit (minimum dimensions shown). Door shown is considered a *Left Hand (LH)* swing.

CAR SIZE	WIDTH	DEPTH	CENTER OF RAIL	CENTER OF DOOR	CLEAR OPENING
48" x 36"	58"	49"	28.5"	34.5"	36"

MINIMUM OVERHEAD CLEARANCE	
CAB	OVERHEAD
80"	102"
84"	106"
95"	117"

ELEVATOR SHAFT REQUIREMENTS			
CAR SIZE	PIT	WIDTH	DEPTH
48" X 36" L/R	12"	58" Min	49" Min / 51" Max

Framing Guidelines

- One wall of the elevator shaft must be properly framed to support the elevator system. See *Figure 1* for detail.
- Typical support wall is the side wall perpendicular to the swing door hinges.
- Pay attention to the door jamb offset. Swing door jambs must be offset as shown in this planning guide and shop drawings.
- Must be able to support 300 lbs. of pullout force, with a maximum deflection on 1/8".

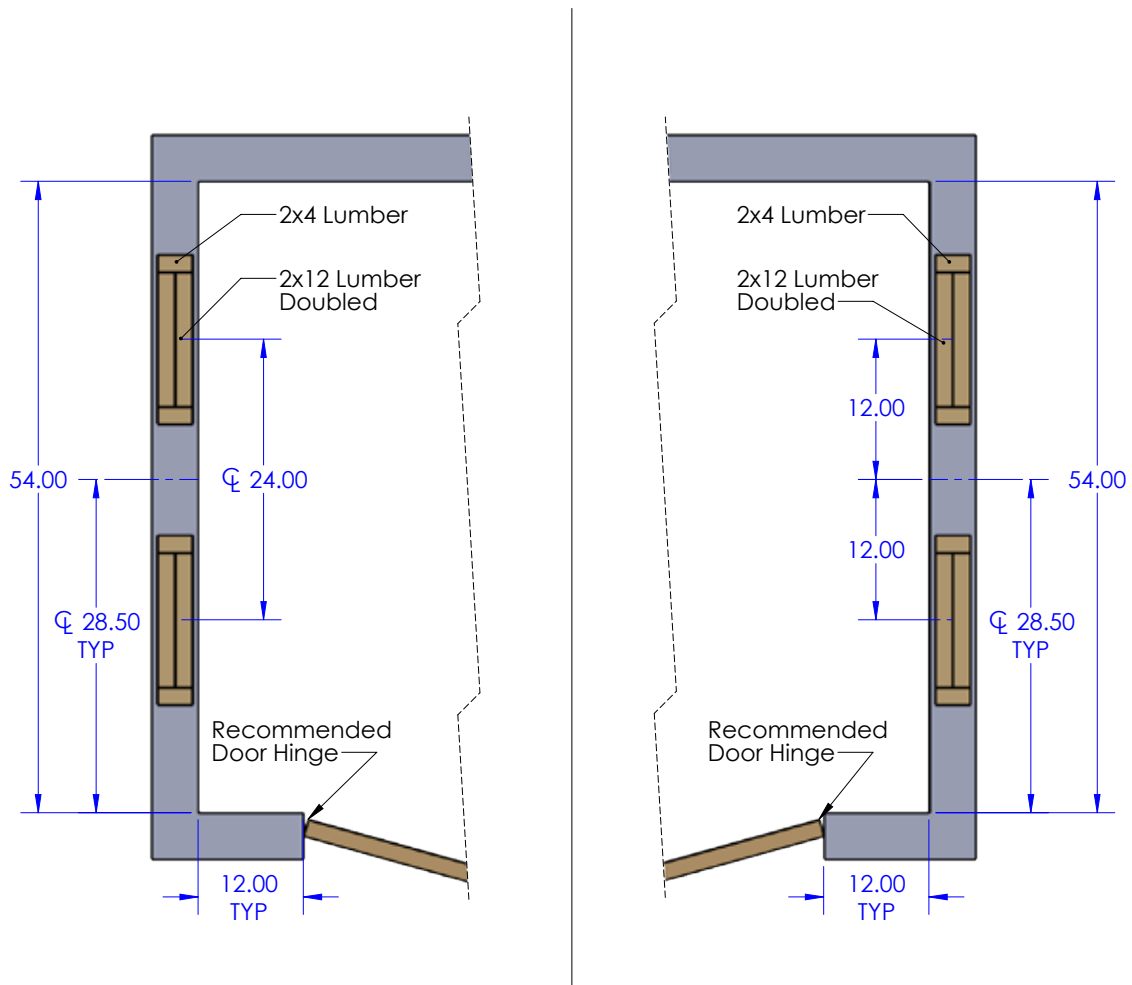

All dimensions are to finished drywall

Figure 1

Support Wall

Recommended method is doubled 2" x 12", with 2" x 4" caps on the ends running vertically from the pit to the very top of the elevator shaft. Boards must be recessed inside the wall (not surface mounted).

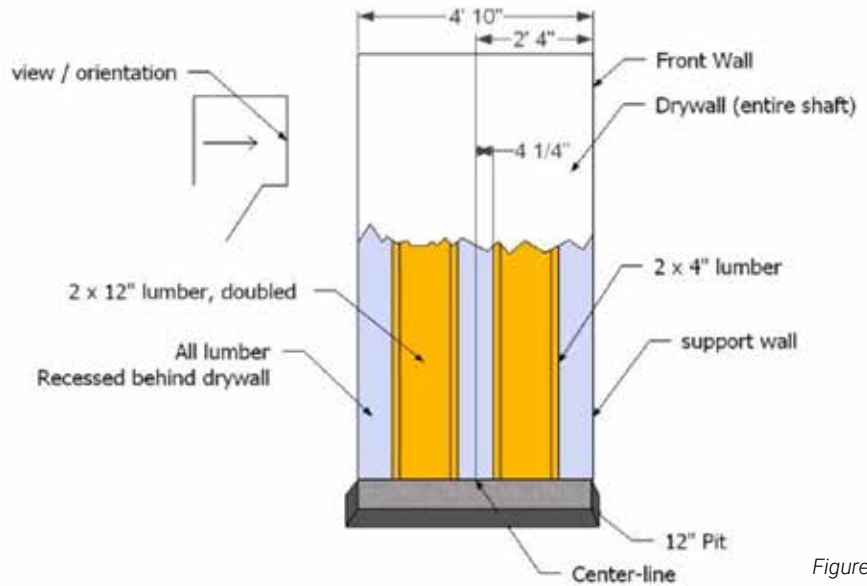

Figure 2

Alternate Framing Options

Alternative method is doubled 2" x 12", running horizontally, recessed inside the wall (not surface mounted) placed every 5' from center to center, starting at the pit floor up to top of hoistway. Top 2" x 12" needs to be 18" down from ceiling to center of 2" x 12".

Alternative method is utilizing masonry shaft construction, and grouting specific cells solid. This will achieve the required pull out forces.

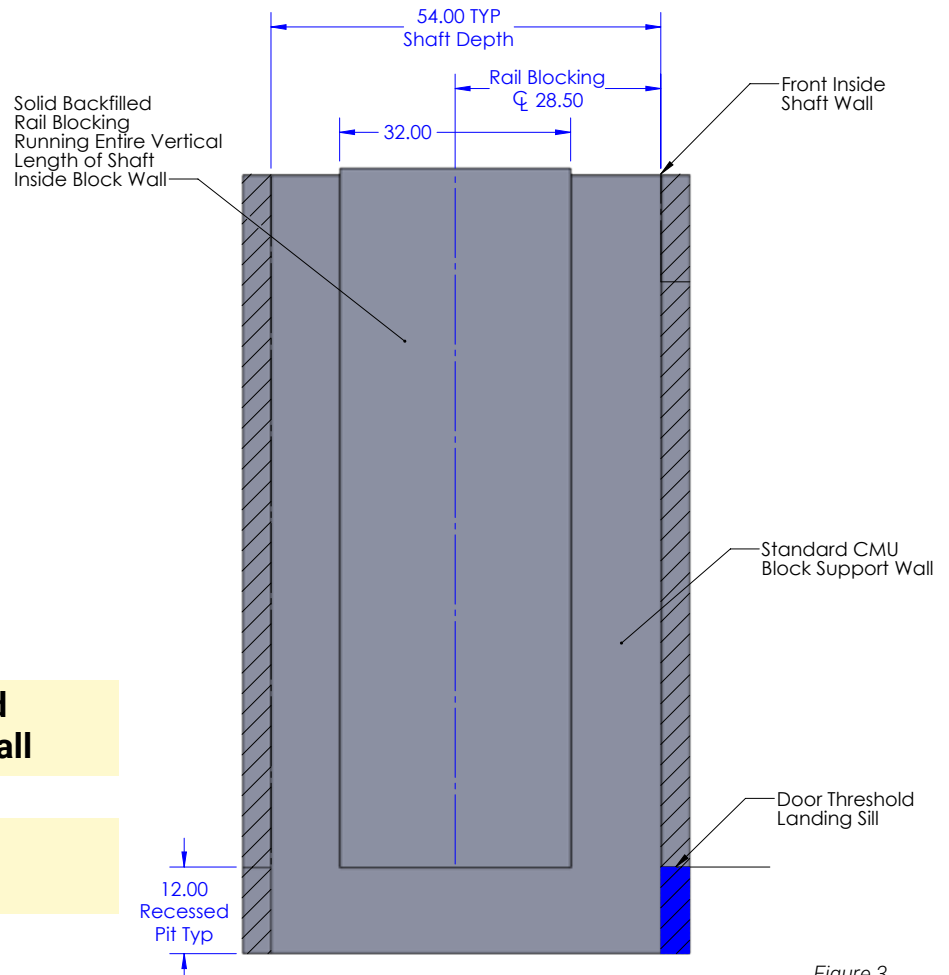

Figure 3

All lumber recessed behind finished drywall

All dimensions are to finished drywall

Shaft Lighting

Shaft lighting may be installed at the very top of the elevator shaft and must be capable of adequately illuminating the entire shaft, first and second floors. *Note: Shaft lighting is required*

Overhead Requirements

All Elevators must have adequate space above the cab for mechanical clearance. This space is referred to as the “overhead clearance”. This is a critical dimension that should be verified and incorporated into the design / building of an elevator shaft. The diagram below shows this requirement when a 96” cab height is chosen. The overhead dimension may be reduced to 102” when a standard 80” can height is used. Please consult the factory or local representative if you are unsure of the overhead dimension, or have a condition that will require special provisions to accommodate a lower overhead clearance.

Access Hatch

An access hatch will be required at the top of the shaft to provide maintenance related and emergency lowering access. *See Figure 4*

Electrical Requirements

Lockable and fusible disconnects should be installed with (1) 230v single phase /30 amp circuit and (1) 110V /15 amp circuit. Disconnects should be located where controller will be installed.

Machine Room

A machine room is not required; however a closet or other suitable location will be required to install the controller to the lift. This should in an easily accessible location for future maintenance and service. The controller may be located in the shaft where allowable by local code authorities.

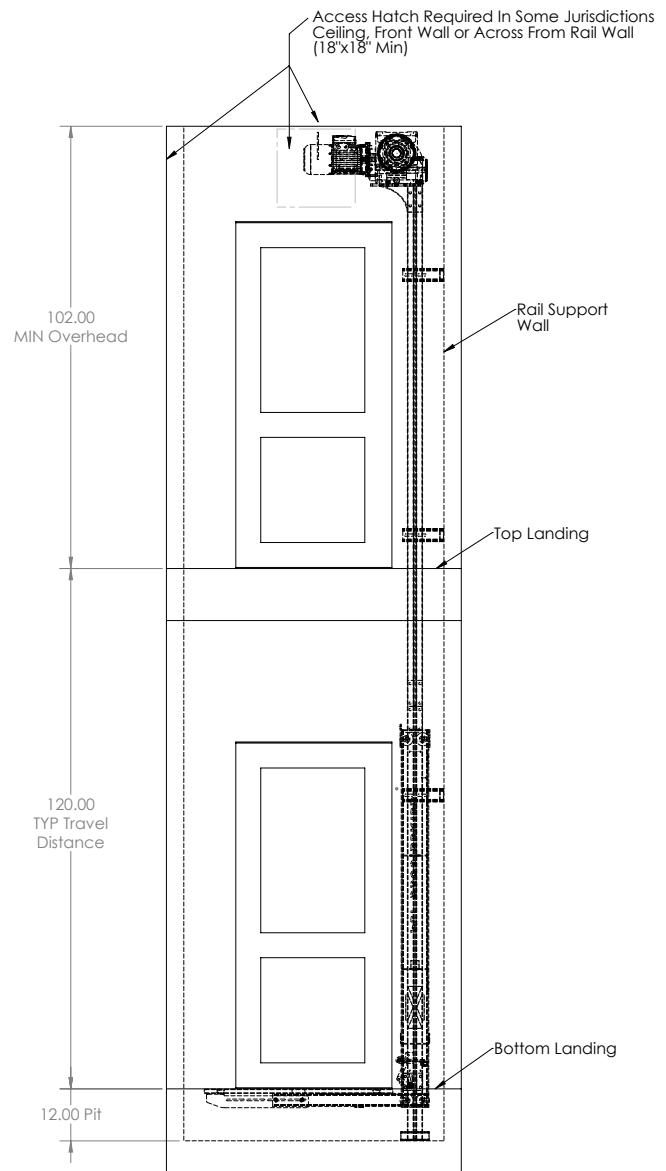
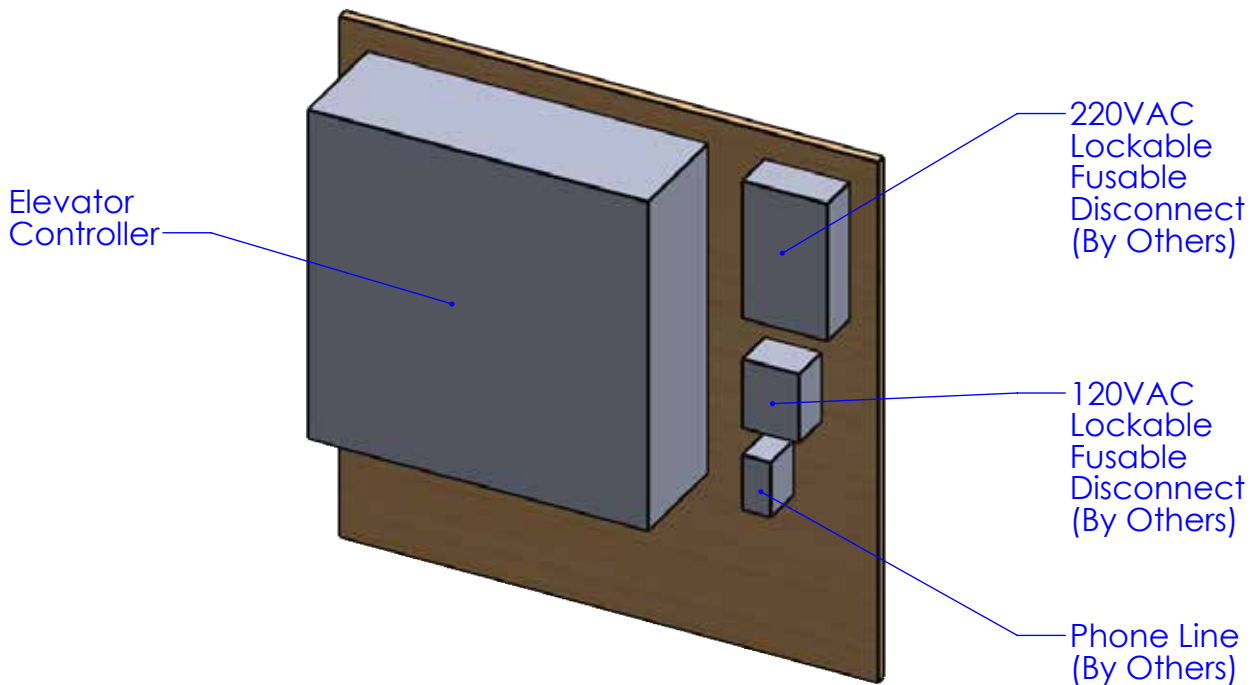
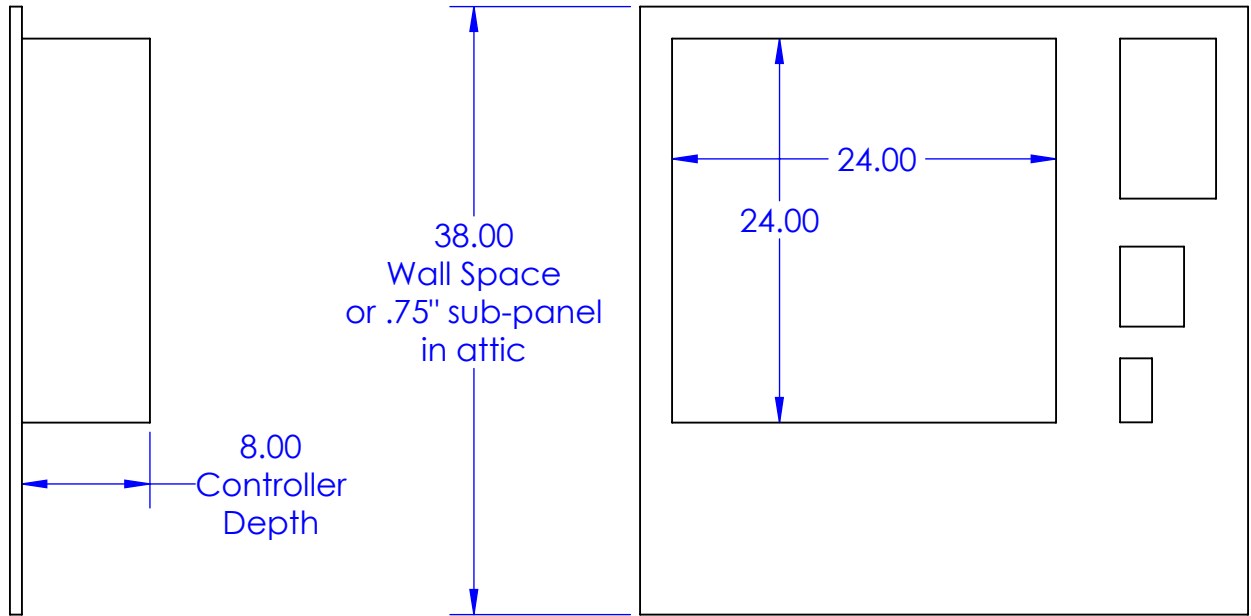

Figure 4 - Required Access Hatch

Controller Layout



Hoistway Doors

Hoistway doors should be solid core construction and are provided by the General Contractor. Hoistway doors must be installed in compliance with the 3-5 Rule as regulated by A17.1 National Elevator Code. A standard hoistway door can be either 80" or 96" in height. *Check Local Requirements*

Figure 5 shows the correct door installation by the general contractor.

Figure 6 shows a common or assumed method of installing the hoistway doors. **It is incorrect and will not meet code.**

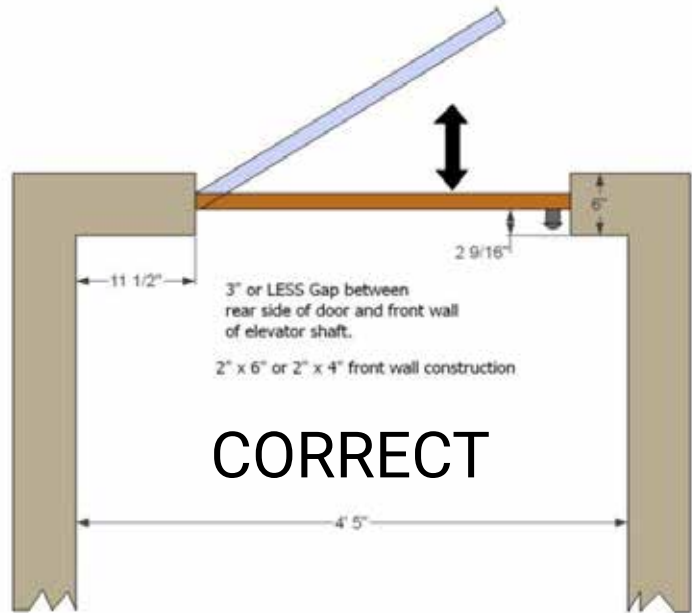

Figure 5 - Correct Door Installation

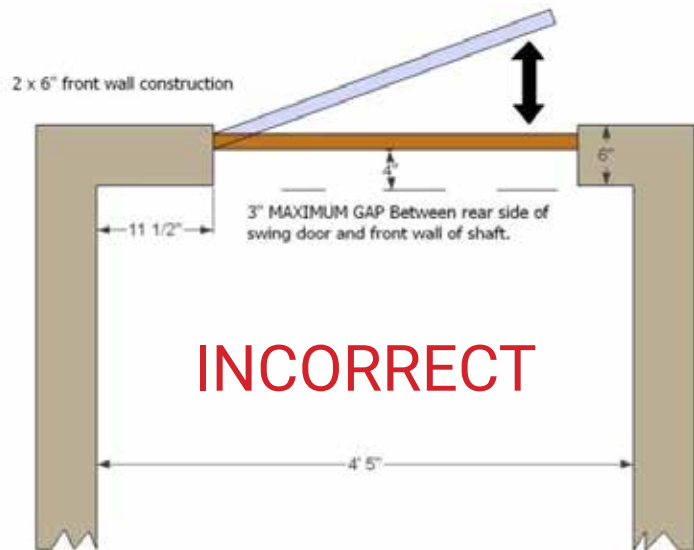

Figure 6 - Incorrect Door Installation

IMPORTANT NOTE

CERTAIN STATES, SUCH AS FLORIDA, GEORGIA AND KENTUCKY, HAVE MORE STRINGENT GUIDELINES FOR DOOR GAP CLEARANCES. FLORIDA, GEORGIA, AND OTHERS, REQUIRE HOISTWAY DOORS TO BE INSTALLED WITHIN 3/4" OF THE ELEVATOR SHAFT WHEN IN THE CLOSED POSITION. THIS REQUIRES SPECIAL DOOR JAM, DOOR KNOB AND INTERLOCK PROVISIONS. CONSULT THE FACTORY FOR MORE DETAILS. SPECIAL FLUSH MOUNT DOOR JAMBS ARE AVAILABLE WHICH INCORPORATE THE INTERLOCK AND BUTTON INTO A UNIQUE JAMB. OWNER/BUILDER THEN PROVIDES A MATCHING DOOR PANEL OF THEIR CHOICE.

Pit Detail

SPECIFICATIONS	
Concrete PSI	3,000
Min Pit Floor Thickness	4.00

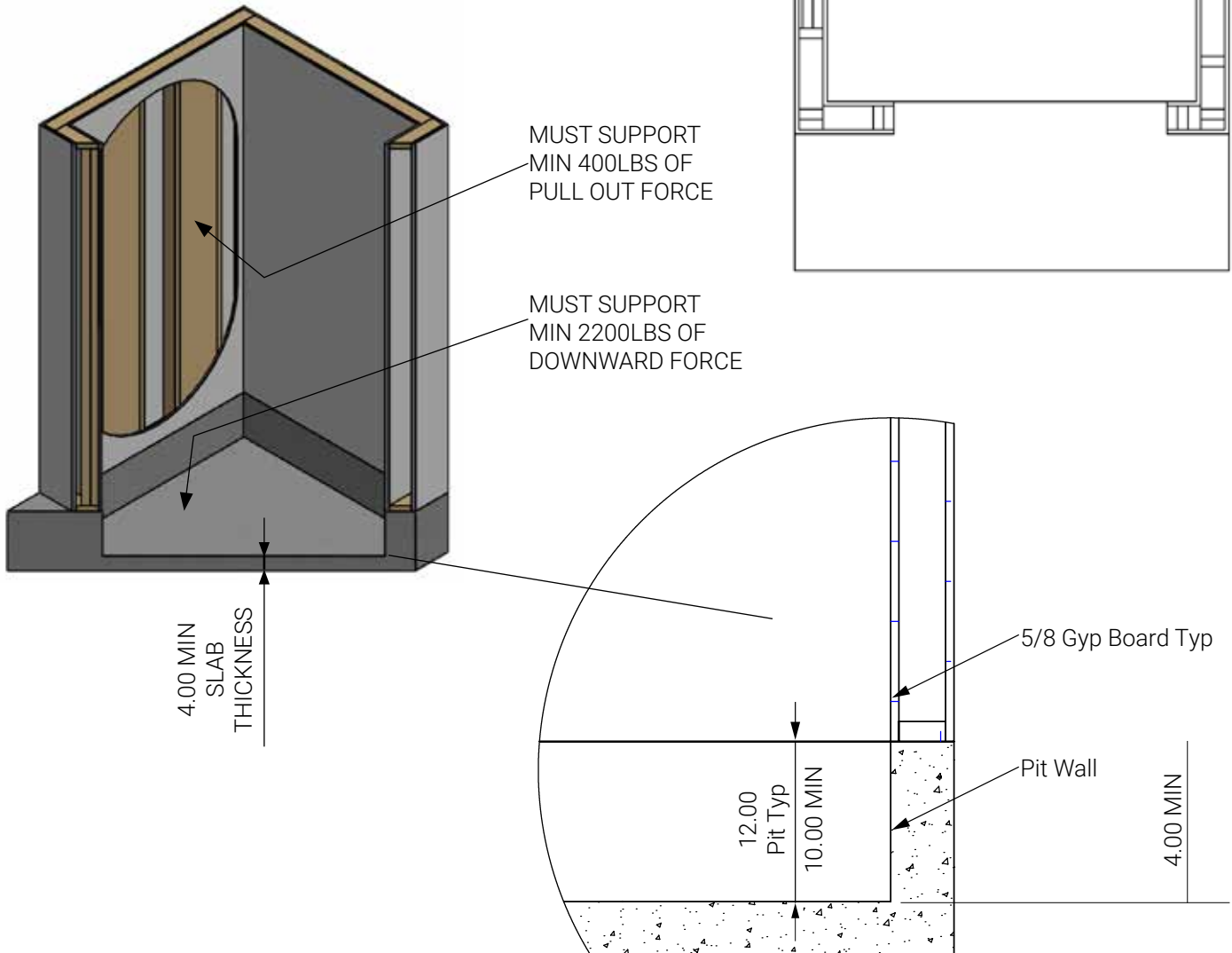
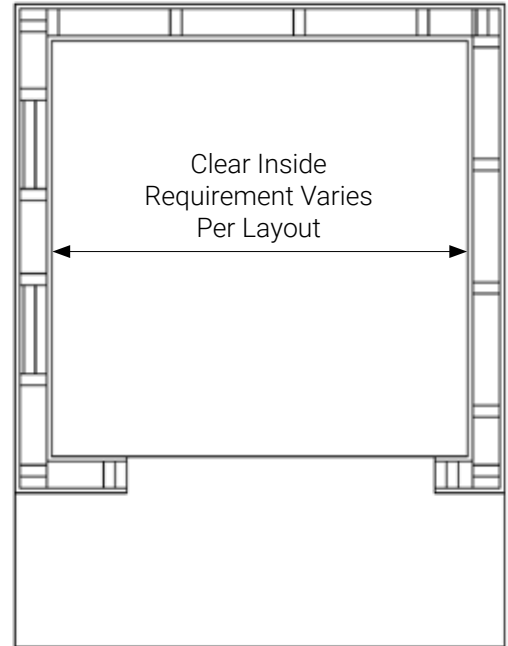



5110 Atlantic Avenue • Raleigh, NC 27616
(855) 595-0281